



Installation Instructions

970 Series Rear Shocks

Harley Davidson V-Rod

ATTENTION

Statements in these instructions that are preceded by the following words are of special significance:

Warning

This means there is the possibility of injury to yourself or others.

Caution

This means there is the possibility of damage to the motorcycle.

Note

Information of particular importance has been placed in italics.

Warranty

Progressive Suspension warrants to the original purchaser of this Part to be free of manufacturing defects in materials and workmanship with a lifetime limited warranty. In the event warranty service is required, you must call Progressive Suspension immediately with a description of the problem.

If it is deemed necessary for Progressive Suspension to make an evaluation to determine whether the part is defective, a return authorization number will be given by Progressive Suspension. The parts must be packaged properly so as to not cause further damage and returned prepaid to Progressive Suspension with a copy of the original invoice of purchase and a detailed letter outlining the nature of the problem. If after the evaluation by Progressive Suspension the part was found to be defective it will be repaired or replaced at no cost to you. If we replace it, we may replace it with a reconditioned one of the same design.

Progressive Suspension shall not be held liable for any consequential or incidental damages resulting from the failure of a Progressive Suspension part. Progressive Suspension shall have no obligation if a part becomes defective as a result of improper installation or abuse.

Warning

Raising or lowering the rear of your motorcycle will affect the steering and initial ground clearance. If the motorcycle is lower to the ground care should be taken to avoid bottoming, especially over bumps or in turns. Raising the rear of a motorcycle can change the steering head angle. Always use extreme caution when riding after a change is made and take time to get accustomed to any handling change.

IMPORTANT NOTICE

Note: Please read the following instructions completely before starting installation!

On the V-Rod models it is necessary to mount the 970 Series reservoirs at the bottom (pointing rearward) to avoid contact with the OE fender.

Follow instructions in an factory authorized shop manual or take the motorcycle to a competent dealer.

Warning

The motorcycle must be securely blocked to prevent it from tipping over when the shocks are removed. Failure to do so can cause serious damage and/or injury.

The use of lowering blocks on Progressive Suspension shocks is not recommended. Use of a lowering kit may void the warranty or damage the shock/motorcycle.

Progressive Suspension shocks are designed to work on the OEM (Original Equipment) frame and swingarm. Use of these shocks on a frame or swingarm other than OEM may produce an unsatisfactory ride and void the warranty.

Make sure that proper bushings/sleeves are installed in the shocks. Improper bushings/sleeves can cause unsatisfactory and/or unsafe operation.

Be sure to refer to instruction supplements, if provided, in any included mounting hardware

Caution

NOTE: The internal pressure and fluid level of your 970 shocks are set from the factory and NOT to be adjusted by the customer. Do NOT attempt to add/remove any fluid or pressure from any fill/bleed ports on the shocks (see below) as damage and/or injury will result and the warranty will be voided.

DO NOT ADJUST/REMOVE

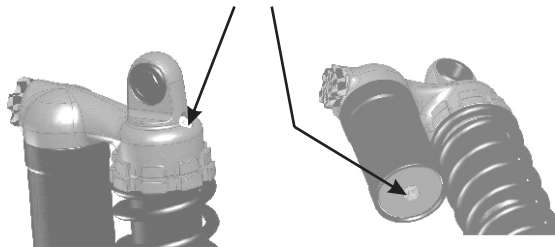

Installation

1. Place a quality jack or sufficient blocks under the motorcycle to securely lift the rear wheel slightly off the ground.
2. Using the correct shop manual for your bike, remove the old shocks and note location of mounting hardware. If additional accessories are installed on your motorcycle, please refer to their mounting instructions for removal to gain access to your shocks.

Installation (continued)

3. Though the 970 Series shocks will work with the reservoirs in any position, on every V-Rod model the reservoirs must be at the bottom facing rearward (as in Figure 1) to avoid contact with the rear fender. It is crucial that the proper sleeves, spacers, and mounting hardware be used at each of the four mounting points - and don't forget to apply a thread-locking agent on each of the shock bolts. On the top mounts, both left & right, the stock bolt first goes through one of the supplied flat-washers, then the shouldered-sleeve installed in the shock eye (with the shoulder towards the frame), then one of the supplied spacers, and finally into the frame (see Figure 2). On the bottom mounts, both left & right, the stock bolt first goes through the stock flat-washer, then the shouldered-sleeve installed in the shock eye (with the shoulder towards the swingarm), and finally into the swingarm - NOTE if the bolt protrudes out the back of the threads (beltguard/nut), install one of the supplied flat-washers between the shouldered sleeve and the swingarm (see Figure 3). Tighten all shock bolts per the torque specification in your factory authorized service manual.

Caution

Remember, things can flex and bushings compress, as a rule try to make sure there is at least .20" (5mm) of clearance all around the shock & reservoir though out the entire stroke. Also if the rear fender or tire has been changed to anything other than stock, double-check the tire to fender clearance making sure that the tire does not come in contact with the fender. In the event that it does, a travel limiter may be required. On some models with side bags or luggage, the bag or luggage mounts may need to be modified to eliminate any interference.

4. Reinstall any accessories removed in accord with their mounting instructions, while watching for possible clearance issues. The bushings in the shock eyes are designed to allow a certain amount of rotation and deflection necessary for proper operation, and binding and/or metal-to-metal contact must NOT occur throughout this range of movement. If any accessories bolt to - or near - the shock mounting points it is crucial that there is no metal to metal contact with a minimum clearance of .02" from the shock be maintained through its range of motion to insure no binding or contact occurs.

5. Set your ride sag. The proper spring pre-load setting will permit the rear suspension to sag, or compress, approximately 1.04"-1.21" (26mm-31mm) from full extension. To check sag, take a measurement from the center of the rear axle, straight up to a vertical point on the rear fender or frame with the shocks fully extended. Then take a second measurement using the same points with the rider(s) on the bike. The difference between the two measurements is the ride sag. If the bike is sagging too much, increase the pre-load.

6. Spring pre-load adjustments are made by using the supplied preload wrench to loosen the preload locking ring, and then turn the preload adjusting ring (Figure 4). Turn this adjuster clockwise (looking at the shock from the reservoir end) to increase spring pre-load and counterclockwise to decrease spring pre-load. Set the pre-load equally on both shocks, measuring the installed spring lengths making sure they are the same. **Never adjust the preload to produce a spring length less than the minimum installed springs listed below for each shock part number, or damage will occur.** Once you've adjusted the preload, be sure to tighten the

Part Number	Minimum Installed Spring Length
970-1011/B-----	6.06" (154mm)
970-1012/B-----	6.54" (166mm)

preload lock ring back down on the adjuster ring.

7. Another adjustment that can be made on your 970 Series shocks is compression damping. Compression damping is the hydraulic force generated by the damper portion of the shock during the compression of the shock. To increase the compression damping, simply turn the knob on the reservoir clockwise and to reduce the compression damping turn it counter clockwise (Figure 5). Adjust both shocks equally by counting the "clicks" from all the way in (MAX compression).

8. Test ride: If excessive bottoming occurs you need to increase your spring pre-load and/or compression setting as described above.

9. Then ride and enjoy.....Safely.

Compliment your new shocks with a set of Progressive Suspension fork springs.

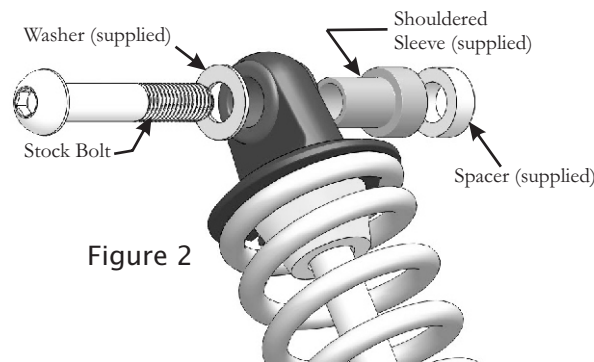

Figure 2

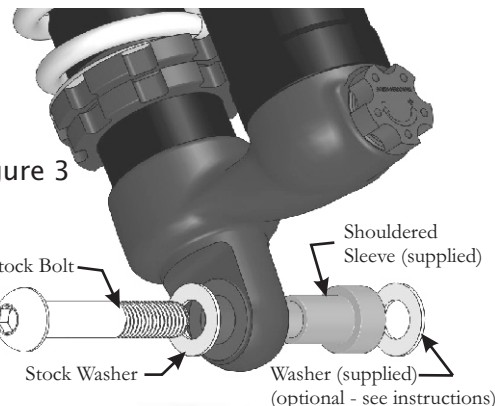

Figure 3

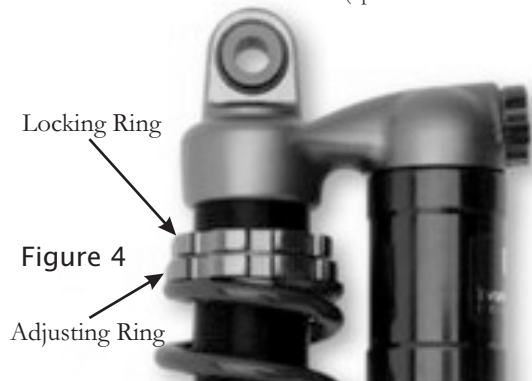

Figure 4



Figure 5