



Installation Instructions 12 Series Rear Shocks

ATTENTION

Statements in these instructions that are preceded by the following words are of special significance:

Warning

This means there is the possibility of injury to yourself or others.

Caution

This means there is the possibility of damage to the motorcycle.

Note

Information of particular importance has been placed in italics.

Warranty

Progressive Suspension warrants to the original purchaser of this Part to be free of manufacturing defects in materials and workmanship with a lifetime limited warranty. In the event warranty service is required, you must call Progressive Suspension immediately with a description of the problem.

If it is deemed necessary for Progressive Suspension to make an evaluation to determine whether the part is defective, a return authorization number will be given by Progressive Suspension. The parts must be packaged properly so as to not cause further damage and returned prepaid to Progressive Suspension with a copy of the original invoice of purchase and a detailed letter outlining the nature of the problem. If after the evaluation by Progressive Suspension the part was found to be defective it will be repaired or replaced at no cost to you. If we replace it, we may replace it with a reconditioned one of the same design.

Progressive Suspension shall not be held liable for any consequential or incidental damages resulting from the failure of a Progressive Suspension part. Progressive Suspension shall have no obligation if a part becomes defective as a result of improper installation or abuse.

Warning

Raising or lowering the rear of your motorcycle will affect the steering and initial ground clearance. If the motorcycle is lower to the ground care should be taken to avoid bottoming, especially over bumps or in turns. Raising the rear of a motorcycle can change the steering head angle. Always use extreme caution when riding after a change is made and take time to get accustomed to any handling change.

IMPORTANT NOTICE

Note: Please read the following instructions completely before starting installation!

These shocks are designed to operate with the shock shaft up. Damage to the shocks may occur if fitted with the shock shaft down.

Follow instructions in an authorized shop manual or take the motorcycle to a competent dealer.

Warning

The motorcycle must be securely blocked to prevent it from tipping over when the shocks are removed. Failure to do so can cause serious damage and/or injury.

The use of lowering blocks on Progressive Suspension shocks is not recommended. Use of a lowering kit may void the warranty or damage the shock/motorcycle.

Make sure that proper bushings/sleeves are installed in the shocks. Improper bushings/sleeves can cause unsatisfactory and/or unsafe operation (see the instructions packaged with the mounting hardware).

Installation

- Place the motorcycle on the centerstand or block the motorcycle securely so the rear wheel is slightly off the ground.
- Remove the old shocks and note location of mounting hardware. If additional accessories are installed on your motorcycle, please refer to their mounting instructions for removal to gain access to the shocks.
- Install one 12 series shock (without springs) and check clearance (#A in Fig. 1). Raise wheel into fender well until shock bottoms. There should be a minimum of 1" of clearance between the tire and fender.
- If clearance (#A) is sufficient, remove the shock and install the springs onto the shock (See Spring Installation) and reinstall the shock onto the motorcycle.

Warning

This step requires a spring compression tool (available from Progressive Suspension, part #32- 5508). If a spring compression tool is not available, refer the work to your local dealer or repair shop. Attempting to compress the springs without the proper tool may result in serious injury!

Installation (cont.)

- Now check clearances (B & C) in figure 1.

(B) Shock to frame at mounting points.

(C) Shock to chain/chain guide, disc caliper and linkage. Also check clearance to any accessories.

Note: The lower shock mounts are offset to allow between the shocks and the motorcycle. Install the shocks with offset towards the motorcycle.

Note: Due to assembly requirements, the bump rubber and washer on the shock shaft are positioned where the washer may rattle slightly. A few miles of normal riding will position the washer where it will cease to rattle. The rattle (if any) will not damage or have any adverse effect on the shock.

Spring Installation (see figure 2):

- Install cam adjuster to the minimum setting (lowest point on preload ramps).
 - Install plastic body protector insuring that the protrusion seats into the cam adjuster.
 - Make sure piston rod is fully extended and bump rubber/washer are pulled down at least 1 inch (25mm).
 - Mounting Springs:
 - If shocks come equipped with single spring only, mount spring on shock and go to Procedure E below.
 - If shocks come with dual springs, install short spring, plastic separator, long spring and go to Procedure E.
 - Install top cap (with decal) and using a spring compressor tool, compress the spring(s) enough to install the retaining clip (F), release the spring slowly, making sure the spring retainer clip seats fully in the top cap and the shock spring.
- Install assembled shock absorbers onto motor cycle and tighten mounting nuts/bolts to proper torque specifications (consult your service manual for correct specifications).
 - Reinstall any accessories removed in accord with their mounting instructions, while watching for possible clearance issues. The bushings in the shock eyes are designed to allow a certain amount of rotation and deflection necessary for proper operation, and binding and/or metal-to-metal contact must NOT occur throughout this range of movement. If any accessories bolt to – or near – the shock mounting points it is crucial that there is no metal to metal contact with a minimum clearance of .02” from the shock be maintained through its range of motion to insure no binding or contact occurs.
 - Make sure both cam adjusters are adjusted to the minimum setting (see figure 3).
 - Test ride.
 - If excess bottoming occurs, adjust preload cam to a higher setting on both shocks. (See Figure 3) If bottoming persists after adjusting to the highest setting, a spring with a higher rate may be required. For easier spring preload adjustments, put a small amount of cam adjuster lube (supplied) on the sliding surface prior to rotating the cam (see figure 4). If excess topping occurs with the cam at the minimum setting, a spring with a lighter rate may be required. Note: The 12 Series Shock has a hydraulic anti-topping design which slows the rebound damping dramatically towards the end of the shock travel. This damping feature helps keep the motorcycle stable as the shock returns from compression.
 - Maintenance: Shock bushings should be checked and cleaned at periodic intervals.
 - For balanced suspension, we highly recommend the installation of a pair of our progressive rate fork springs.

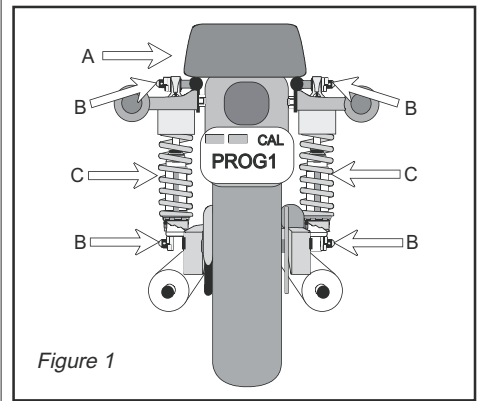

Figure 1

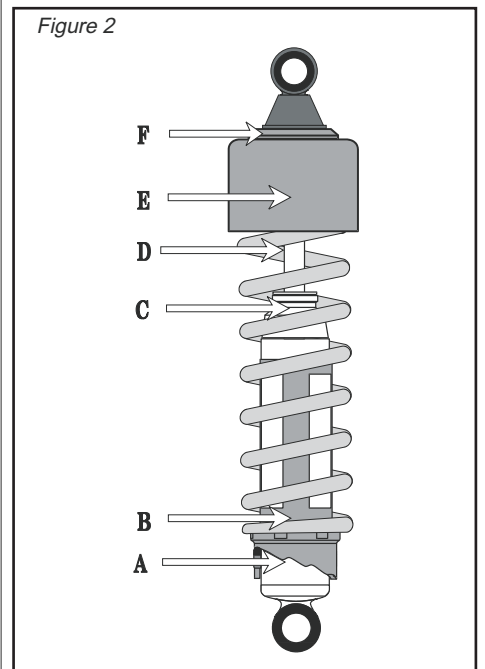

Figure 2

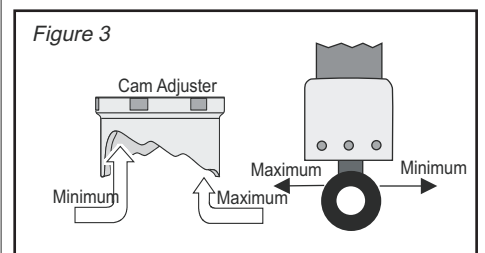

Figure 3

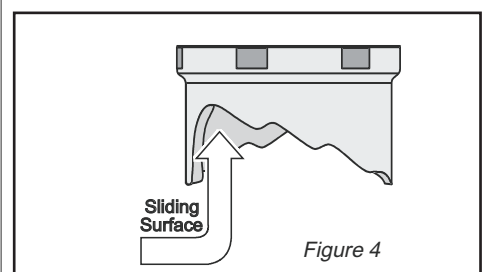

Figure 4