



Installation Instructions Fork Spring Kit BMW F800GS

ATTENTION

Statements in these instructions that are preceded by the following words are of special significance:

Warning

This means there is the possibility of injury to yourself or others.

Caution

This means there is the possibility of damage to the vehicle.

Note

Information of particular importance has been placed in italics.

Lifetime Limited Warranty

Progressive Suspension warrants to the original purchaser this Part to be free of manufacturing defects in materials and workmanship with a lifetime limited warranty. In the event warranty service is required, you must call Progressive Suspension immediately with a description of the problem.

If it is deemed necessary for Progressive Suspension to make an evaluation to determine whether the part is defective, a return authorization number will be given by Progressive Suspension. The parts must be packaged properly so as to not cause further damage and returned prepaid to Progressive Suspension with a copy of the original invoice of purchase and a detailed letter outlining the nature of the problem. If after the evaluation by Progressive Suspension the part was found to be defective it will be repaired or replaced at no cost to you. If we replace it, we may replace it with a reconditioned one of the same design.

Progressive Suspension shall not be held liable for any consequential or incidental damages resulting from the failure of a Progressive Suspension part. Progressive Suspension shall have no obligation if a part becomes defective as a result of improper installation or abuse.

Warning

Changing the chassis and/or suspension on any vehicle will change the handling characteristics of that vehicle. Care should be taken when operating the vehicle with such modifications while getting accustomed to the new handling characteristics.

IMPORTANT NOTICE

Caution: Removing and replacing fork springs must be performed by a qualified mechanic or according to steps outlined in a professional workshop manual that relates to your particular make, model and year motorcycle.

The vehicle must be securely blocked to prevent it from dropping or tipping when the fork springs are removed. Failure to do so can cause serious damage and/or injury.

Progressive Suspension Fork Springs are designed to work with the OEM (Original Equipment) forks. Use of this product on any forks other than OEM may produce an unsatisfactory ride and void the warranty.

Installation

- Read all the instructions carefully before installing this kit on your motorcycle. Use your factory authorized manual as a reference while installing this kit.
- Support and lift the motorcycle securely so the front wheel is off the ground. The balance point is toward the front of the engine.
- Remove the stock fork springs as well as the spring guides and preload spacers (under the fork springs) according to instructions contained in your factory authorized shop manual. The Progressive Suspension fork spring kit is a direct replacement of your stock springs. You will also be replacing the stock spring guides and preload spacers with the ones supplied in this kit.
- Before installing the new springs & preload spacers, it is crucial that you make sure you've installed the proper fluid and the fluid level is correct. We recommend a 7wt. fork fluid. To check the fluid level properly you must have the springs and spacers removed and the fork completely compressed. You then measure from the top of the fork leg to the fluid level - the recommend measurement is 90mm. Add or remove fluid to achieve this measurement.

Note

For maximum performance we highly recommend that the forks be disassembled and thoroughly cleaned, inspected and new fork oil installed - we recommend a 7wt. fork oil. See fine tuning for more information. Fork oil level should be measured with the fork springs & preload spacers removed and the fork completely compressed. The measurement from the top edge of the fork leg to the fluid level should be 90mm.

Caution

NEVER ADD TOO MUCH FLUID RESULTING IN A MEASUREMENT LESS THAN 90mm WHEN USING THIS SPRING KIT

- After confirming the fork fluid level, install the supplied preload spacers, spring-guides, and Progressive Suspension fork springs - tighter coils down - into the forks in the same manner you would install the stock components per your factory authorized shop manual - essentially replacing the stock preload spacers, spring guides, and springs with the supplied Progressive Suspension components (see illustration).
- Reinstall the fork cap being certain to torque it to the factory specification noted in your factory authorized shop manual. Reinstall any other components previously removed per a factory authorized shop manual. Remove motorcycle from lift and re-check all fasteners for proper tightness per your factory authorized manual.
- Technical info: Our technical staff will assist you if you have any problems or questions. Call (714) 523-8700 from 8 am to 4 PM Pacific time.
- The operator must use extreme caution when operating a modified motorcycle, particularly while getting familiar with its altered handling characteristics and ground clearance.

FINE TUNING

- Fork Oil: Though we recommend using a 7wt. fork fluid, oil viscosity can be changed to alter damping. Heavier oil to increase damping. Lighter oil to decrease damping. Increase in 2.5 weight increments (i.e. from 2.5 weight to 5 weight.) Oil viscosity will have more effect on rebound damping than compression damping, too high a viscosity can create harshness on sharp edge bumps. The oil level also affects the ride, too high an oil level and the forks will feel too stiff, too low an oil height and the bike will bottom and feel soft or dive excessively. As stated previously, when using this spring kit **NEVER adjust the fork oil level to produce a measurement of less than 90mm - measured fork springs removed, fork compressed, from the top of the fork leg - or damage will occur.**

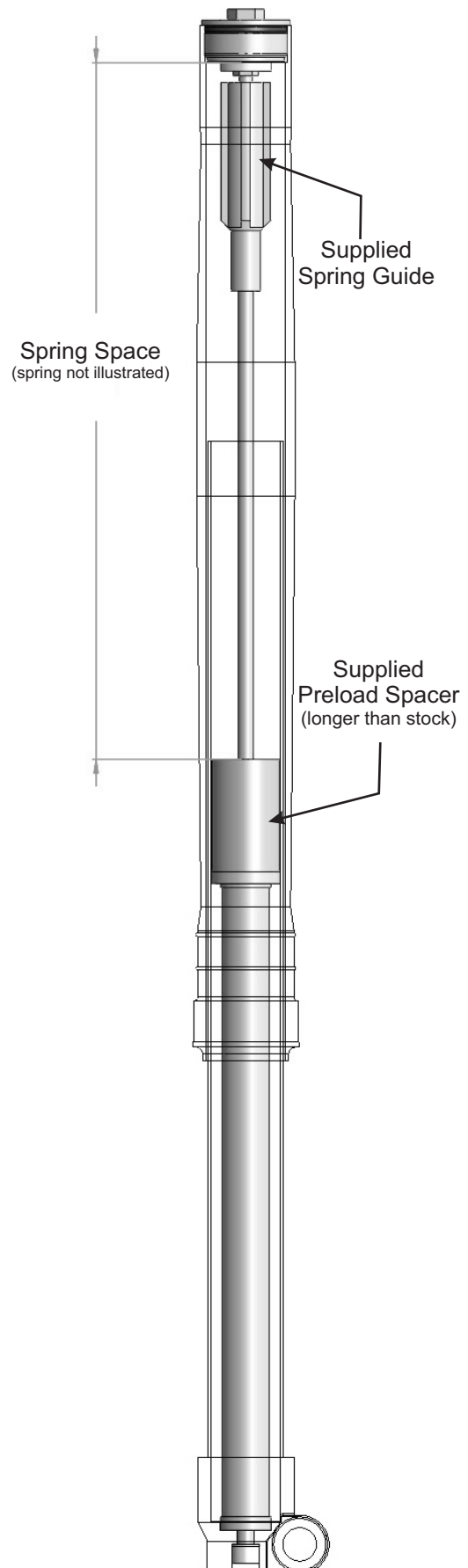

(Illustration NOT to scale)

