



Installation Instructions Kawasaki EX 650 428 Series Rear Shock

ATTENTION

Statements in these instructions that are preceded by the following words are of special significance:

Warning

This means there is the possibility of injury to yourself or others.

Caution

This means there is the possibility of damage to the motorcycle.

Note

Information of particular importance has been placed in italics.

Warranty

Progressive Suspension warrants to the original purchaser of this Part to be free of manufacturing defects in materials and workmanship with a 2 year limited warranty. In the event warranty service is required, you must call Progressive Suspension immediately with a description of the problem.

If it is deemed necessary for Progressive Suspension to make an evaluation to determine whether the part is defective, a return authorization number will be given by Progressive Suspension. The parts must be packaged properly so as to not cause further damage and returned prepaid to Progressive Suspension with a copy of the original invoice of purchase and a detailed letter outlining the nature of the problem. If after the evaluation by Progressive Suspension the part was found to be defective it will be repaired or replaced at no cost to you. If we replace it, we may replace it with a reconditioned one of the same design.

Progressive Suspension shall not be held liable for any consequential or incidental damages resulting from the failure of a Progressive Suspension part. Progressive Suspension shall have no obligation if a part becomes defective as a result of improper installation or abuse.

Warning

Changing the suspension or chassis on your motorcycle will affect the handling characteristics. Always use extreme caution when riding after a change is made and take time to get accustomed to any handling change.

IMPORTANT NOTICE

Note: Please read the following instructions completely before starting installation!

This shock is designed to be mounted with the body at the top and the shaft at the bottom.

Follow instructions in an authorized shop manual or take the motorcycle to a competent dealer.

Warning

The motorcycle must be securely blocked to prevent it from tipping over when the shock is removed. Failure to do so can cause serious damage and/or injury.

The use of lowering blocks on Progressive Suspension shocks is not recommended. Use of a lowering kit may void the warranty or damage the shock/motorcycle.

Progressive Suspension shocks are designed to work on the OEM (Original Equipment) frame and swingarm. Use of this shock on a frame or swingarm other than OEM may produce an unsatisfactory ride and void the warranty.

Make sure that proper bushings/sleeves are installed in the shock. Improper bushings/sleeves can cause unsatisfactory and/or unsafe operation (see step 4).

Installation

1. Place a quality jack or sufficient blocks under the motorcycle to securely lift the rear wheel slightly off the ground.
2. Using the correct shop manual for your bike, remove the old shock and note location of mounting hardware. If additional accessories are installed on your motorcycle, please refer to their mounting instructions for removal to gain access to your shock.
3. Before installing your new Progressive shock you need to check the tire to fender clearance, making sure that the tire does not come in contact with the fender. If the rear fender or tire has been changed to anything other than stock, a travel limiter may be required. On some models with side

bags or luggage, the bag or luggage mounts may need to be modified to eliminate any interference.

4. Shouldered sleeves with O-rings should already be installed in the mounting eyes of your new 428 shock. There should be two shouldered sleeves in each eye - the two wider ones go in the bottom/rear eye and the two narrower sleeves go in the upper/front eye. If they are not, insert sleeves with O-rings into the shock eye (figure 1).

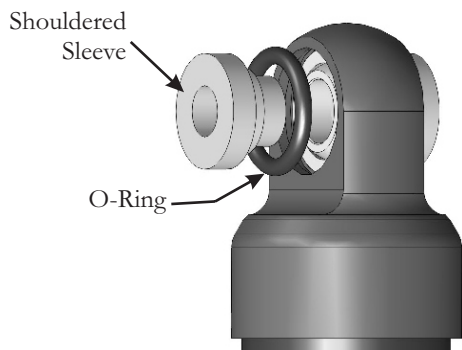

Figure 1

5. Install the shock assembly onto the motorcycle. Orient the shock similar to the OE unit, with the body end up/forward and the shaft end down/reward. Also note that the nitrogen valve should be facing up. Tighten bolts / nuts to their proper torque. Check the clearances of the shock to the frame, make sure no possible contact can be made with the frame, wiring, brake lines, etc. (figure 2)

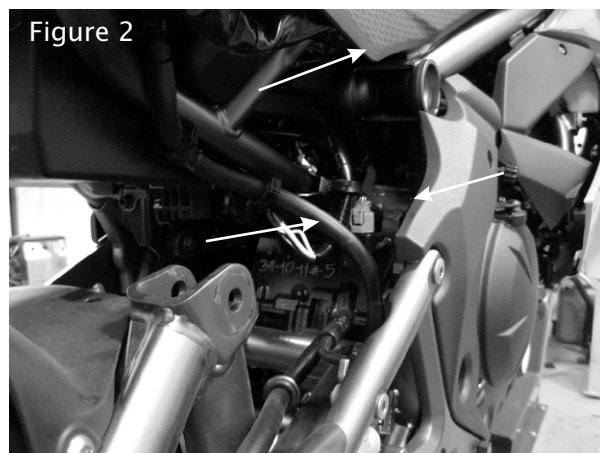

Figure 2

6. Reinstall any accessories removed in accord with their mounting instructions. Make sure accessories do not interfere with the shock throughout its full travel. If any accessories bolt to the shock mounting points, a careful inspection must be made to insure that they do not bind the shock in any way.

7. Set your ride sag. The proper spring pre-load setting will permit the rear suspension to sag, or compress, approximately 1.3" from full extension. To check sag, take a measurement from the center of the rear axle, straight up to a vertical point on the rear fender or frame with the shock fully extended. Then take a second measurement using the same points with the rider(s) on the bike. The difference between the two measurements is the ride sag. If the bike is sagging too much, increase the pre-load - not sagging enough, reduce it.

8. Spring pre-load adjustments are made by using the supplied preload wrench to loosen the preload locking ring, and then turn the preload adjusting ring. Turn this adjuster clockwise (looking at the shock from the body end) to increase spring pre-load and counterclockwise to decrease spring pre-load. Never adjust the preload to produce a spring length less than the minimum installed springs lengths listed below for each shock part number, or damage will occur. Once you've adjusted the preload, be sure to tighten the preload lock ring back down on the adjuster ring.

Part Number	Minimum Installed Spring Length
428-1000	5.58" inches (142mm)
428-1001	5.29" inches (134mm)

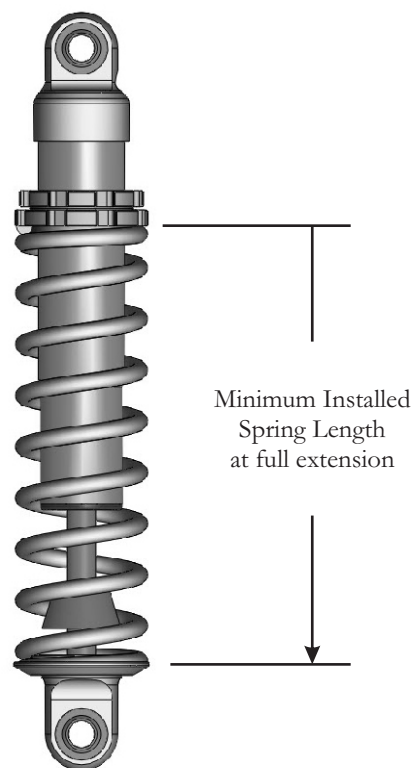

9. Test ride: If excessive bottoming occurs you may increase your spring pre-load to improve bottoming control.

10. Then ride and enjoy.....Safely.

Compliment your new shock with a set of Progressive Suspension fork springs.