



6911 Marlin Circle, La Palma, CA 90623
(714) 523-8700, Fax (714) 523-3220

BMW K75/K100 465 Series Single Shock Supplement

Please read these instructions completely before starting!

1. Shouldered sleeves with O-rings should already be installed in the shock eye. If not, insert sleeves with O-rings in the top eye (see figure 1).

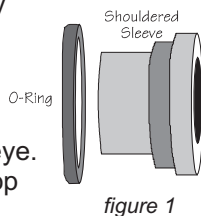

figure 1

2. Mount the shock per figure 2 (shaft end facing up). Make sure rebound adjustment is mounted so it is at the top facing the rear. Torque shock bolts to the proper torque specifications (refer to authorized shop manual).

Caution: The installed spring length must never be set shorter than 7.12" or shock damage may occur.

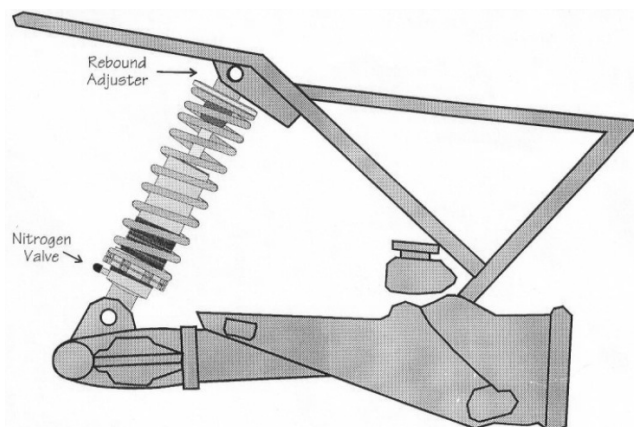

Figure 2

<http://www.progressivesuspension.com>



6911 Marlin Circle, La Palma, CA 90623
(714) 523-8700, Fax (714) 523-3220

BMW K75/K100 465 Series Single Shock Supplement

Please read these instructions completely before starting!

1. Shouldered sleeves with O-rings should already be installed in the shock eye. If not, insert sleeves with O-rings in the top eye (see figure 1).

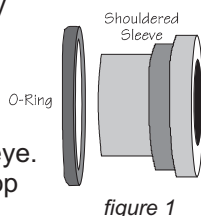

figure 1

2. Mount the shock per figure 2 (shaft end facing up). Make sure rebound adjustment is mounted so it is at the top facing the rear. Torque shock bolts to the proper torque specifications (refer to authorized shop manual).

Caution: The installed spring length must never be set shorter than 7.12" or shock damage may occur.

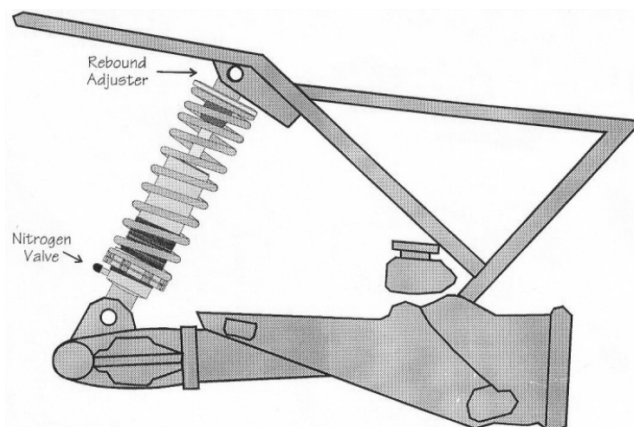

Figure 2

<http://www.progressivesuspension.com>